

N-Channel Enhancement Mode Field Effect Transistor

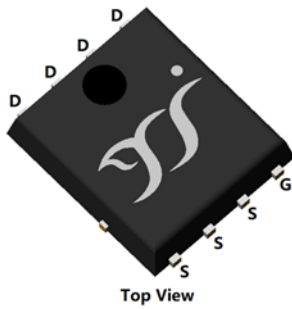

Top View

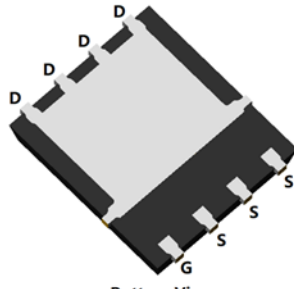

Bottom View

PDFN5060-8L

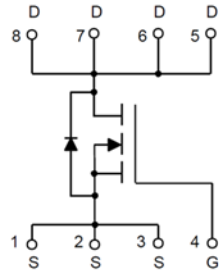

Product Summary

- V_{DS} 60V
- I_D 95A
- $R_{DS(ON)}$ (at $V_{GS}=10V$) <2.5 mohm
- $R_{DS(ON)}$ (at $V_{GS}=4.5V$) <3.4 mohm
- 100% EAS Tested
- 100% ∇V_{DS} Tested

General Description

- Split Gate Trench MOSFET technology
- Excellent package for heat dissipation
- High density cell design for low $R_{DS(ON)}$
- Moisture Sensitivity Level 1
- Epoxy Meets UL 94 V-0 Flammability Rating
- Halogen Free

Applications

- DC-DC Converters
- Power management functions
- Synchronous-rectification applications

■ Absolute Maximum Ratings ($T_A=25^\circ\text{C}$ unless otherwise noted)

Parameter	Symbol	Limit	Unit
Drain-source Voltage	V_{DS}	60	V
Gate-source Voltage	V_{GS}	± 20	V
Drain Current (Silicon limited)	I_D	155	A
Drain Current ^A	I_D	$T_C=25^\circ\text{C}$	95
		$T_C=100^\circ\text{C}$	60
Pulsed Drain Current ^B	I_{DM}	390	A
Avalanche energy ^C	EAS	500	mJ
Total Power Dissipation ^D	P_D	120	W
Thermal Resistance Junction-to-Case	$R_{\theta JC}$	1.04	$^\circ\text{C}/\text{W}$
Thermal Resistance Junction-to-Ambient ^E	$R_{\theta JA}$	20	
Junction and Storage Temperature Range	T_J, T_{STG}	-55~+150	$^\circ\text{C}$

■ Ordering Information (Example)

PREFERRED P/N	PACKING CODE	Marking	MINIMUM PACKAGE(pcs)	INNER BOX QUANTITY(pcs)	OUTER CARTON QUANTITY(pcs)	DELIVERY MODE
YJG95G06A	F1	YJG95G06A	5000	10000	50000	13" reel



YJG95G06A

■ Electrical Characteristics (T_J=25 °C unless otherwise noted)

Parameter	Symbol	Conditions	Min	Typ	Max	Units
Static Parameter						
Drain-Source Breakdown Voltage	BV _{DSS}	V _{GS} = 0V, I _D =250μA	60			V
Zero Gate Voltage Drain Current	I _{DSS}	V _{DS} =60V, V _{GS} =0V			1	μA
Gate-Body Leakage Current	I _{GSS}	V _{GS} = ±20V, V _{DS} =0V			±100	nA
Gate Threshold Voltage	V _{GS(th)}	V _{DS} = V _{GS} , I _D =250μA	1.2	1.6	2.5	V
Static Drain-Source On-Resistance	R _{DS(ON)}	V _{GS} = 10V, I _D =20A		2.1	2.5	mΩ
		V _{GS} = 4.5V, I _D =15A		2.7	3.4	
Diode Forward Voltage	V _{SD}	I _S =20A, V _{GS} =0V			1.2	V
Maximum Body-Diode Continuous Current	I _S				95	A
Dynamic Parameters						
Input Capacitance	C _{iss}	V _{DS} =25V, V _{GS} =0V, f=100KHZ		5950		pF
Output Capacitance	C _{oss}			1250		
Reverse Transfer Capacitance	C _{rss}			85		
Switching Parameters						
Total Gate Charge	Q _g	V _{GS} =10V, V _{DS} =50V, I _D =50A		93		nC
Gate-Source Charge	Q _{gs}			17		
Gate-Drain Charge	Q _{gd}			14		
Reverse Recovery Chrage	Q _{rr}	I _F =25A, di/dt=100A/us		73		
Reverse Recovery Time	t _{rr}			68		
Turn-on Delay Time	t _{d(on)}	V _{GS} =10V, V _{DD} =30V, I _D =25A R _{GEN} =2Ω		22.5		ns
Turn-on Rise Time	t _r			6.7		
Turn-off Delay Time	t _{d(off)}			80.3		
Turn-off fall Time	t _f			26.9		

Note:

- The maximum current rating is package limited.
- Repetitive rating; pulse width limited by max. junction temperature.
- V_{DD}=50 V, R_G=25 Ω, L=0.5mH, starting T_J=25 °C.
- P_D is based on max. junction temperature, using junction-case thermal resistance.
- The value of R_{θJA} is measured with the device mounted on 1 in 2 FR-4 board with 2oz. Copper, in a still air environment with T_a=25 °C.



YJG95G06A

■ Typical Performance Characteristics

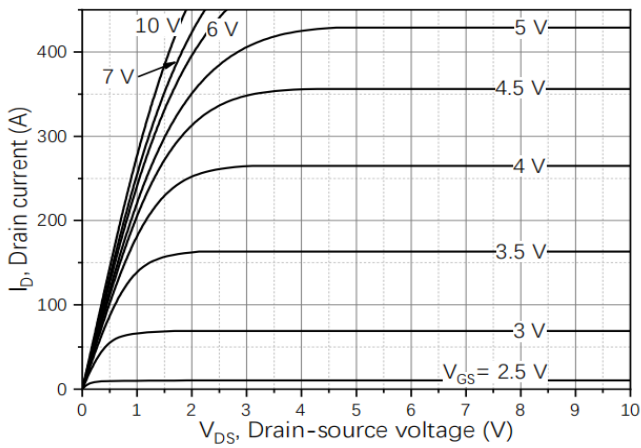

Figure1. Output Characteristics

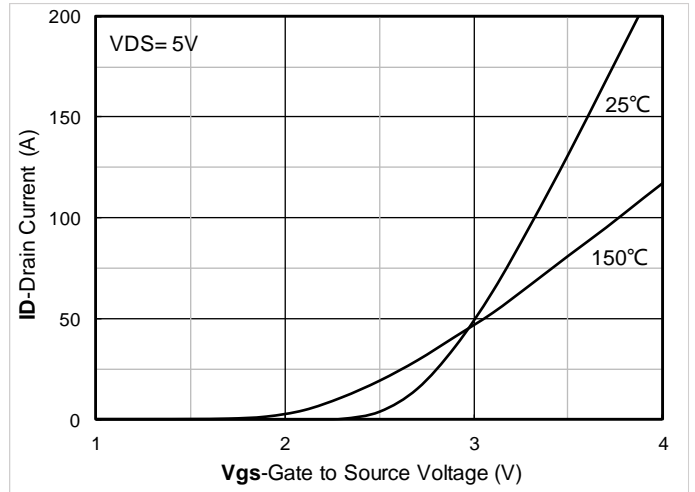

Figure2. Transfer Characteristics

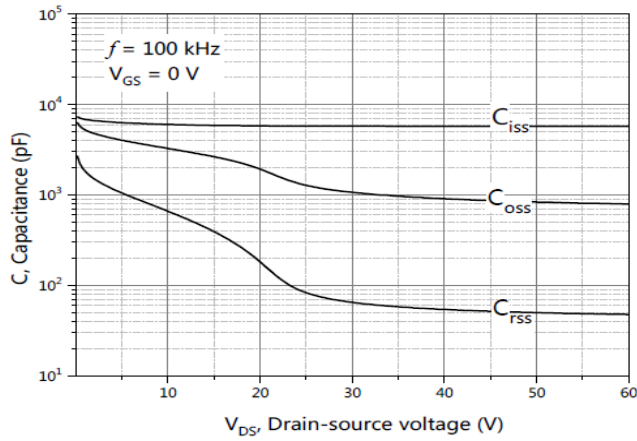

Figure3. Capacitance Characteristics

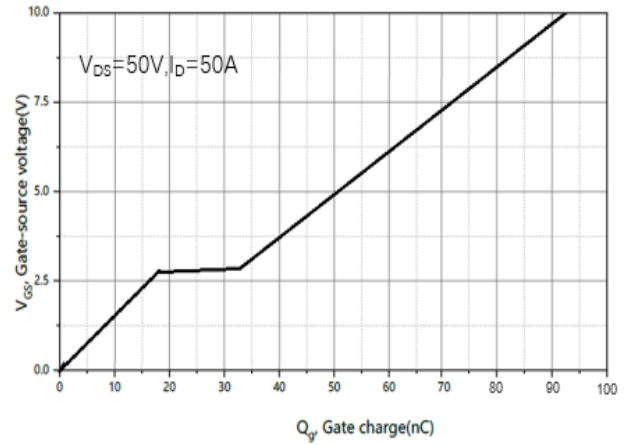

Figure4. Gate Charge

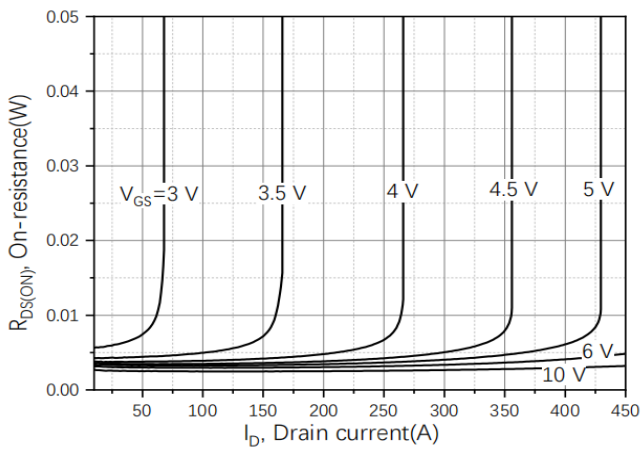

Figure5. Drain-Source on Resistance

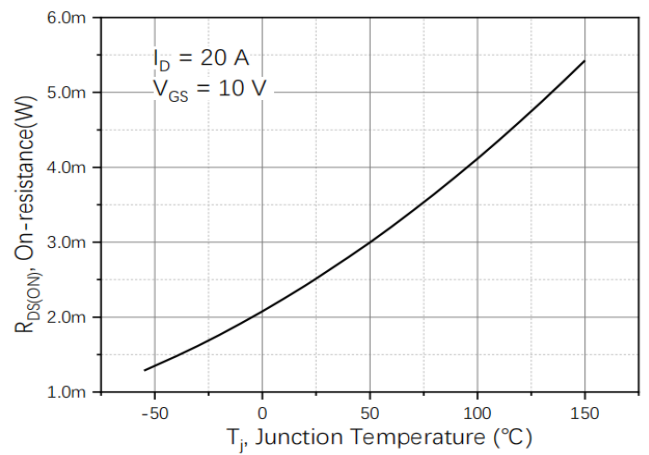

Figure6. Drain-Source on Resistance



YJG95G06A

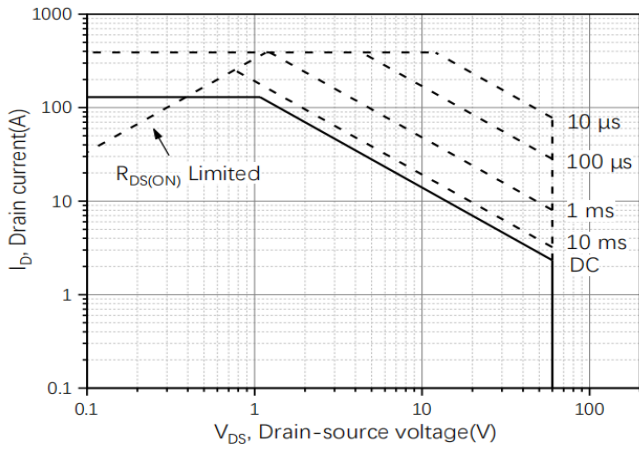

Figure 7. Safe Operation Area

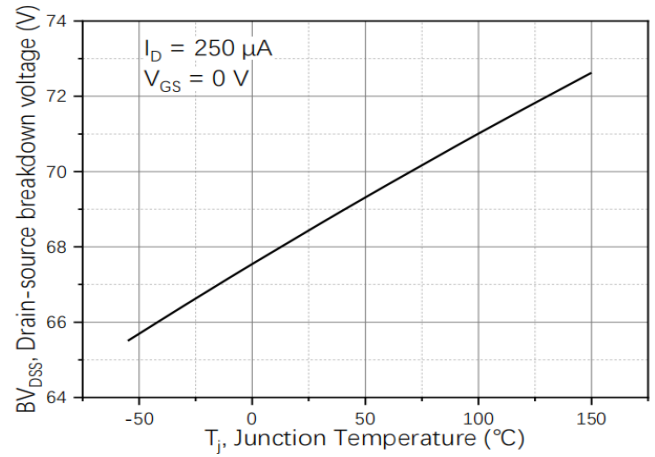

Figure 8. Drain-source breakdown voltage

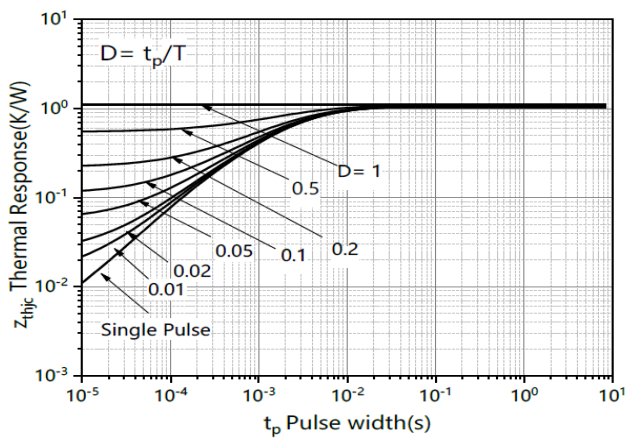

Figure 9. Transient thermal impedance

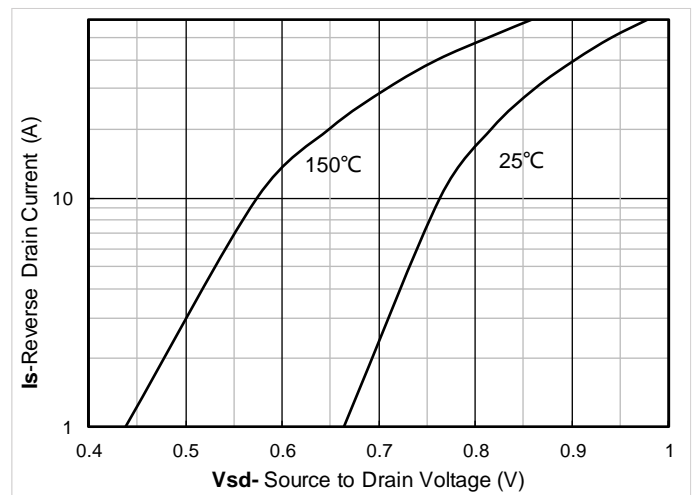

Figure 10. Forward characteristics of reverse diode

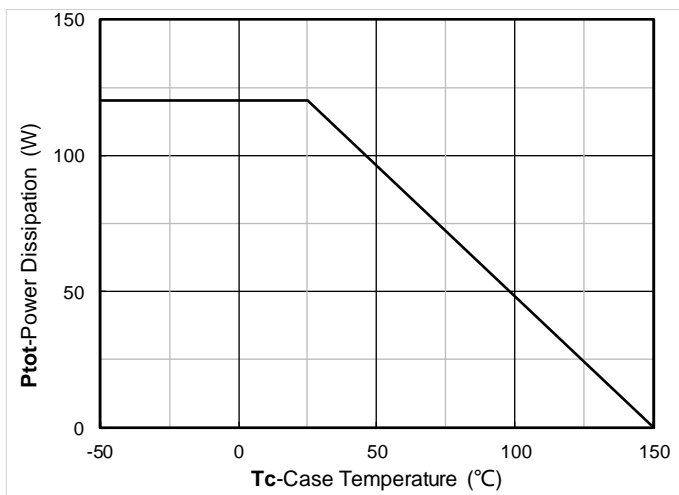

Figure 11. Power dissipation

■ Test circuits and waveforms

Figure A: Gate Charge Test Circuit & Waveforms

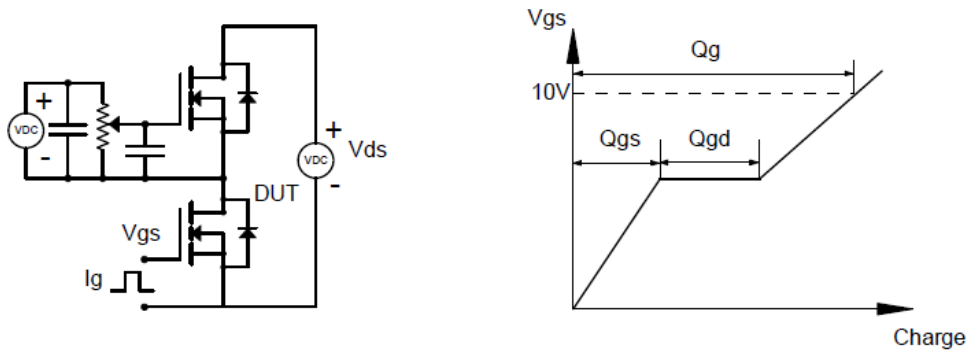

Figure B: Resistive Switching Test Circuit & Waveforms

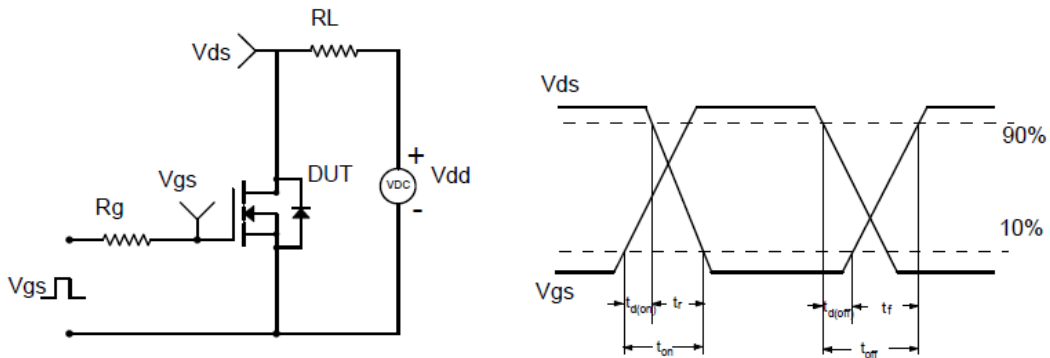

Figure C: Unclamped Inductive Switching (UIS) Test

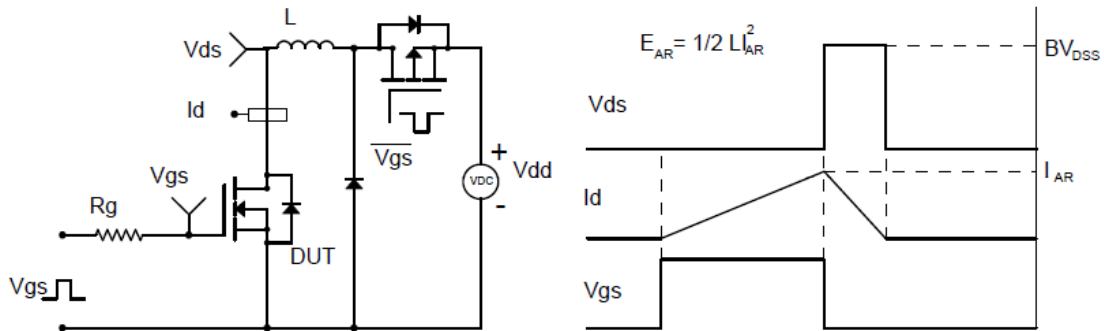
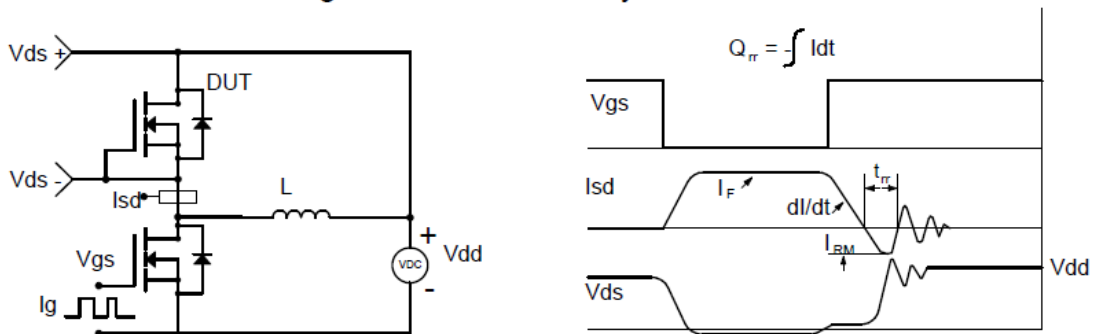

Figure D: Diode Recovery Test Circuit & Waveforms





YJG95G06A

■ PDFN5060-8L-B-1.1MM Package Information

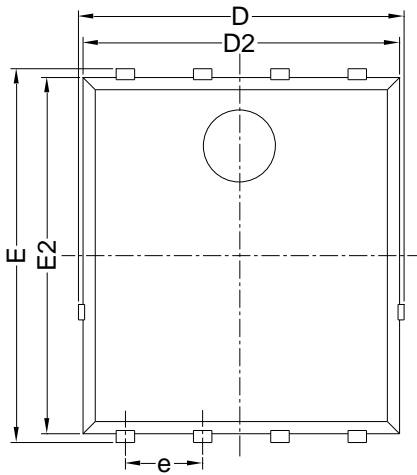

Top View
正面视图

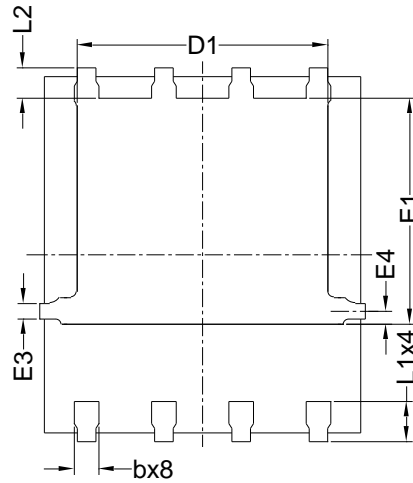

Bottom View
背面视图

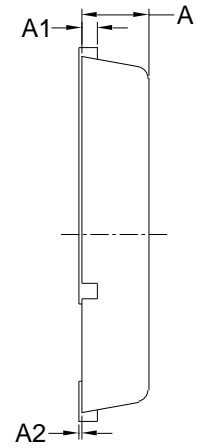

Side View
侧面视图

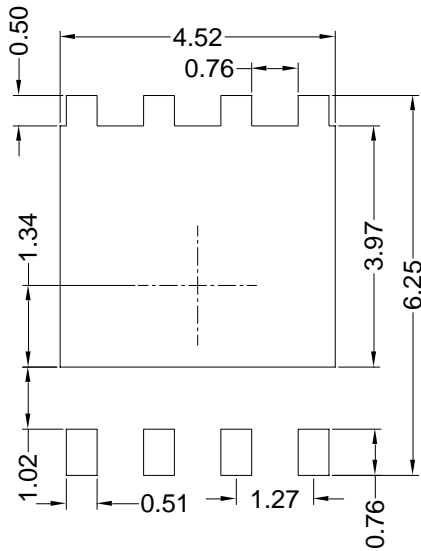

Suggested Solder Pad Layout
Top View

SYMBOL	MILLIMETER		
	MIN	NOM	MAX
D	5.15	5.35	5.55
E	5.95	6.15	6.35
A	1.00	1.10	1.20
A1	0.254 BSC		
A2			0.10
D1	3.92	4.12	4.32
E1	3.52	3.72	3.92
D2	5.00	5.20	5.40
E2	5.66	5.86	6.06
E3	0.254 REF		
E4	0.21 REF		
L1	0.56	0.66	0.76
L2	0.50 BSC		
b	0.31	0.41	0.51
e	1.27 BSC		

Note:

1. Controlling dimension: in millimeters.
2. General tolerance: ± 0.10 mm.
3. The pad layout is for reference purposes only.



YJG95G06A

Disclaimer

The information presented in this document is for reference only. Yangzhou Yangjie Electronic Technology Co., Ltd. reserves the right to make changes without notice for the specification of the products displayed herein to improve reliability, function or design or otherwise.

The product listed herein is designed to be used with ordinary electronic equipment or devices, and not designed to be used with equipment or devices which require high level of reliability and the malfunction of which would directly endanger human life (such as medical instruments, transportation equipment, aerospace machinery, nuclear-reactor controllers, fuel controllers and other safety devices), Yangjie or anyone on its behalf, assumes no responsibility or liability for any damages resulting from such improper use of sale.

This publication supersedes & replaces all information previously supplied. For additional information, please visit our website [http:// www.21yangjie.com](http://www.21yangjie.com) , or consult your nearest Yangjie's sales office for further assistance.